

**SCHLAGE**

## AD-400

Networked wireless  
electronic lock



### Overview

AD Series electronic locks from Schlage® are designed to be modular and provide more options to choose from, more functionality in the lock and more compatibility with existing systems. Its patented modular design allows the lock to be customized to fit the needs of an application now, and changed to meet future needs without removing it from the door.

Factory orderable options include choices of credential readers, chassis type, network configurations, locking functions, power options, lever styles and finishes. It also offers a wide selection of features that can be configured in the field to customize your openings.

To simplify installation, the AD Series combines all the hardware components required at the door for a complete access control system into one integrated design that includes the electrified lock, credential reader, request-to-exit and request-to-enter sensors, door position switch, tamper guard and more.

The AD-400 wireless networked lock gives you many of the key benefits of a hardwired access control system — without the wires. This allows you to secure doors that were traditionally difficult to run wires to in the past—and increase the security throughout your facility.

The AD-400 has a number of features built in, that are configurable in the field and a long list of items that can be monitored by access control software. Please consult one of our Physical Access Control Software (PACS) providers for details on the integration of specific features.

### Features and benefits

- Open architecture platform
- Panel interface options ensure seamless communication with your system
- Non-invasive installations for historic buildings and sensitive areas
- Secure encrypted data transmission
- Unique communication protocols that won't interfere with other wireless networks
- Patent-pending wireless feature enables centralized lockdown in less than 10 seconds while still optimizing battery life up to 2 years
- Wireless accessories available for remote, gate, elevator and portable (mustering) applications
- Compatible with NFC mobile credentials on iOS and Android platforms<sup>1</sup>
- ANSI/BHMA A156.25, ANSI/BHMA Grade 1, UL 294, UL10C, FCC Part 15, ADA, Industry Canada (IC), FL12400<sup>2</sup>, FL1591<sup>2</sup>, FL13013<sup>2</sup> and FL14482<sup>2</sup>

<sup>1</sup> Check with PACS provider for specific support of Mobile Student IDs in Apple Wallet and Google Pay

<sup>2</sup> Applies to cylindrical and mortise chassis only

### **CYBERSECURITY**

Learn about Allegion's commitment

## Reliable communications

Secure and reliable wireless communication with the Panel Interface Module (PIM) is accomplished using 900 MHz frequency. 900 MHz band enables longer transmission ranges because signal propagation with longer wavelengths travel a greater distance and better penetrate typical building construction – allowing for simplified system design.

## Wake-Up on Radio

This feature enables implementation of wireless locks in applications where centralized lockdown or unlock is required. 'Wake Up on Radio' utilizes patent-pending technology to enable real-time activation at a remote battery-powered wireless lock. The technology is configurable from 10 to 1 second increments. When Wake-Up on Radio is used in critical applications Dynamic Channel Switching should also be enabled.

## Panel Interface Module (PIM400)

The PIM400 (sold separately) is required for communication between the AD-400 wireless lock and the access control panel, and can support up to 16 locks depending on your access control system.

## AD-400 electronic lock specifications

Modulation	900 MHz spread spectrum, direct sequence, 10 channels
Frequency range	902-928 MHz
Transmission/encryption	AES-128 bit key
Credential verification time	< 1 second <sup>1</sup>
Wake-Up on Radio	Responds to lock/unlock command from host in less than 10 seconds in battery powered applications (per field configuration)
Communication range	Up to 200 ft with obstructions (normal building construction), up to 1000 ft clear line of sight
RF interference avoidance	Configurable dynamic channel switching
Data rate	RF: 40 kbps
Visual/audible communications	Tri-colored LED's and audible indicators (field configurable)
System interface	RS-485, Wiegand, or Clock & Data via PIM400 to host
Power supply	4AA, 8AA, 12 VDC or 24 VDC
Voltage range	4 VDC to 26 VDC
Max current requirement	Up to 250 mA
Battery life	Up to 2 yrs with 4AA
Operating temperature/ exterior	-31° to 151°F (-35° to 66°C)
Operating temperature/ interior	32° to 120°F (0° to 49°C) (battery)
Operating humidity	0 - 100% non-condensing
Certifications	ANSI/BHMA A156.25, ANSI/BHMA Grade 1, UL 294, UL10 C, FCC Part 15, ADA
Accessories	Panel Interface Module (PIM400), SUS-A Cable used with SUS Android mobile app, remote antennas for PIM400 to extend range, Dry Contact Relay Board (RLBD) may be required for supervised inputs (Wiegand systems)

### Functions

- Classroom/storeroom<sup>2</sup>
- Office<sup>2,3</sup>
- Privacy<sup>3</sup>
- Apartment<sup>3</sup>

### Available status signals

- Lock/unlock status<sup>4</sup>
- Request-to-exit
- Door position
- Mechanical key override<sup>3</sup>
- Deadbolt position<sup>3</sup>
- Interior push button<sup>3</sup>
- Interior cover tamper guard<sup>3</sup>
- Battery status
- Communication status<sup>3</sup>
- Request-to-enter<sup>3</sup>

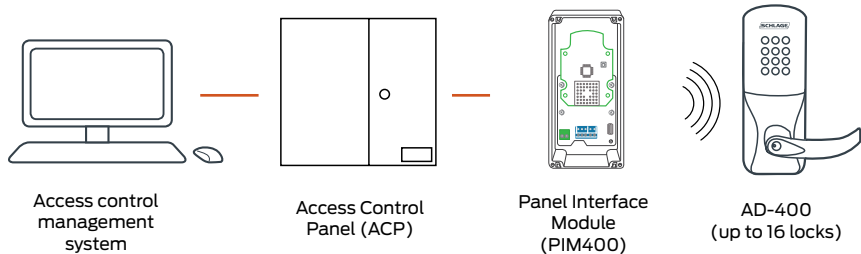
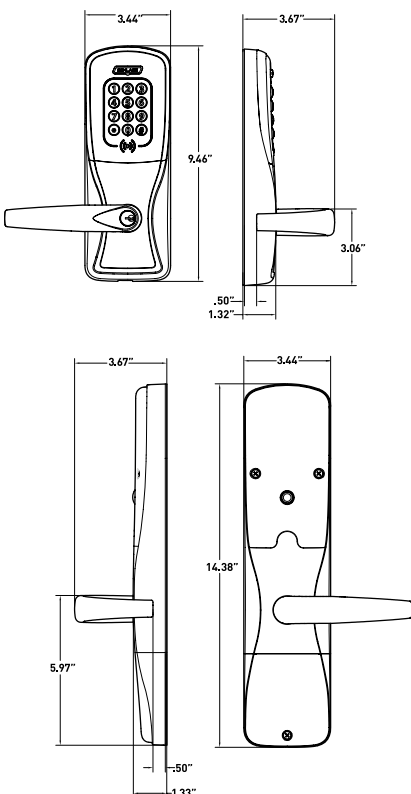

<sup>1</sup> Lock requires less than 100 msec, response time does not include latency time of ACP.

<sup>2</sup> Classroom/storeroom and office function not available with mortise deadbolt option.

<sup>3</sup> Consult your Physical Access Control Software (PACS) provider for specific scope of support. Interior pushbutton, mechanical key override and deadbolt position are only available when linked via PIM400-485.

<sup>4</sup> Software indicates lock/unlock status based on sequence of events, but cannot validate mechanical clutch position unless monitored on RS-485 connection.

## Mechanical specifications

Chassis	Cylindrical	Mortise	Exit trim
Handing	Handed to order, field reversible		
ANSI standard (Meets or exceeds)	A156.25 A156.2 Series 4000 Grade 1	A156.25 A156.13 Series 1000 Grade 1	A156.25 A156.3
Door thickness	1 3/4" standard, 1 3/8" to 2 3/4" optional (available in 1/8" increments)		
Backset	Standard: 2 3/4" Optional: 2 3/8", 3 3/4", 5"	2 3/4" only	Defined by exit device
Latch bolt	Standard: 1/2" throw Optional: 3/4" throw	Standard: 3/4" throw Optional: 1" throw on mortise deadbolt	Provided by exit device
Levers	Pressure cast zinc, plated		
Strike	Standard: 1 3/16" lip, ANSI, 1 1/4" x 4 7/8" Optional: Additional configurations available please see price book		Provided by exit device
Cylinder and keys	Schlage® 6-pin Everest 29 S123 keyway Conventional cylinder with two patented keys standard. Additional options available including SFIC, FSIC and competitor brands. See lever and cylinder compatibility data sheet (010432)		

## Multi-technology reader specification

Credential technologies	Proximity (125 kHz), Smart (13.56 MHz) and Near Field Communication (NFC)
Standards	ISO 15693 ISO 14443
Read range	Proximity: up to 1.25" Smart: up to .75" NFC mobile: mobile device dependent
Proximity credential compatibility	<b>Compatibility:</b> Schlage, ISONAS™, HID®, GE/CASI ProxLite®, AWID® and LenelProx® <b>Schlage credential style formats:</b> Clamshell, ISO card, ISO card with magnetic stripe, keyfob, thin keyfob, PVC adhesive disk
Smart credential compatibility	<b>Secure sector compatibility:</b> Schlage MIFARE Classic®, Schlage MIFARE Plus®, Schlage MIFARE® DESFire® EV1 and EV2 with PACSA, PIV and PIV-I <sup>1</sup> <b>CSN only compatibility:</b> DESFire, HID iClass®, Inside Contactless Pico Tag®, MIFARE, MIFARE DESFire EV1 and EV2, ST Microelectronics®, Texas Instruments Tag-It®, Phillips I-Code® <b>Schlage credential style formats:</b> Clamshell, ISO card, ISO card with magnetic stripe, keyfob, thin keyfob, wearable wristband, PVC patch
Mobile credential compatibility	NFC-enabled mobile devices <sup>3</sup>
Certifications/standards	FCC, Industry Canada (IC), UL 294 Listed, ISO standard 15693 and ISO standard 14443
Options	12 button, 3x4 matrix backlit keypad

<sup>1</sup> FIPS 201-2 integration ready option available: The AD Series can be used in applications which require approval by the U.S. Federal Government under HSPD-12 for FIPS 201-2 compliance when installed as part of a tested and approved integrated solution. Please see the AD-402 data sheet or AD-302 data sheet for complete details.

<sup>2</sup> 75 bit output format default. Configurable to other output formats.

<sup>3</sup> Check with PACS provider for specific support of Mobile Student IDs in Apple Wallet and Google Pay.

## Available AD Series reader modules



### Multi-technology

- Proximity
- Smart card
- NFC mobile

KEYPAD



### Multi-technology

- Proximity
- Smart card
- NFC mobile



### Smart – iClass compatible

- Smart card
- NFC mobile

KEYPAD



### Smart – iClass compatible

- Smart card
- NFC mobile



### Magnetic stripe (insertion)

- KEYPAD



### Magnetic stripe (insertion)



### Magnetic stripe (swipe)

- KEYPAD



### Magnetic stripe (swipe)



### Keypad

## AD Series exit trim:

AD-400 exit trim is exclusively compatible with Von Duprin 98/99 and 98/99XP (Rim, Mortise, and SVR. CVC and CVR on metal doors only), Von Duprin 22/22F (Rim and SVR) and Falcon 25 (Rim) exit devices made by Allegion. The proper low current request-to-exit switch (RX-LC or AE) is required.

Part numbers for request-to-exit switch:

- Von Duprin: 050281
- Falcon: 650359

## Benefits of AD Series multi-technology readers:

- Reads multiple brands of both proximity (125 kHz) and smart (13.56 MHz) technologies with single reader
- Compatible with NFC mobile credentials on iOS and Android platforms<sup>3</sup>
- Allows facility to migrate to more secure credential technologies over time and as budgets permit

## Additional readers

### Smart – iClass compatible

- Reads secure sector of HID iClass, iClass SE, iClass SEOS, iClass Standard Key, and iClass Elite Key; Schlage MIFARE Classic, MIFARE Plus, and MIFARE DESFire EV1 and EV2
- Reads NFC mobile credential, Bluetooth mobile credential not supported
- Proximity not supported

### Magnetic stripe

- Available with choice of insertion or swipe style readers
- Triple track reader (1, 2 or 3), field configurable
- ABA, ISO76XX standard

### Keypad

- Backlit keypad
- 12 button, 3x4 matrix

# Ordering information

Available through one of our GSA schedule 84 approved distributions; BAA options available

AD-400-CY-70-MG-SPA-626-P6-S123-RH-4B-13-049-10-025-1 3/4

Series	Class	Chassis	Function	Reader	Lever style	Finish	Lever cylinder	Keying type	Handing	Battery	Backset & latch	Strike	Door thickness
1	2	3	4	5	6	7	8	9	10	11	12	13	14

## Selections correspond with the numbers above

Standard options are indicated in bold. See price book for specific configuration options.

<b>3</b>	<b>Chassis</b>
CY	Cylindrical
MS	Mortise
MD	Mortise deadbolt
993R	Exit trim – Rim/CVC/CVR
993S	Exit trim – SVR
993M	Exit trim – mortise
993DT	Non-functioning dummy trim for exit
<b>4</b>	<b>Function</b>
70	Classroom/storeroom
50	Office
40	Privacy
60	Apartment
Lock function capabilities are determined by users access control system	
<b>5</b>	<b>Reader</b>
<b>KP</b>	<b>Keypad</b>
MG	Magnetic stripe (insertion)
MGK	Magnetic stripe + keypad (insertion)
MS	Magnetic stripe (swipe)
MSK	Magnetic stripe + keypad (swipe)
MT	Multi-technology
	(125 kHz, 13.56 MHz, NFC)
MTK	Multi-technology + keypad
	(125 kHz, 13.56 MHz, NFC)
FMK	FIPS 201-1 compliant
	multi-technology + keypad
	(125 kHz and 13.56 MHz)
Si	Smart–iClass compatible
SiK	Smart–iClass compatible + keypad
DT	Dummy trim

<b>6</b>	<b>Lever</b>
ATH	Athens
BRK	Boardwalk
BRW	Broadway
LAT	Latitude
LON	Longitude
RHO	Rhodes
SPA	Sparta
TLR	Tubular
Available with tactile warning options	
<b>7</b>	<b>Finish</b>
<b>626</b>	<b>Satin chrome</b>
605	Bright brass
606	Satin brass
612	Satin bronze
619	Satin nickel
625	Bright chrome
643e	Aged bronze
626AM	Satin chrome antimicrobial
<b>8</b>	<b>Lever cylinder type</b>
<b>P6</b>	<b>Schlage 6-pin Conventional key-in-lever cylinder</b>
See price book for other SFIC, FSIC and less cylinder options available. Compatible with Schlage®, Sargent®, Corbin Russwin, Medeco® and Yale®.	
<b>9</b>	<b>Keyway type</b>
<b>S123</b>	<b>Everest 29</b>
See price book for other available keyway options including restricted keyways in Primus XP high security cylinders and master keying	
<b>10</b>	<b>Handing</b>
<b>RH</b>	<b>Right handed</b>
LH	Left handed
Field reversible	

<b>11</b>	<b>Battery</b>
<b>4B</b>	<b>4AA</b>
8B	8AA
<b>12</b>	<b>Backset &amp; latch or armor front</b>
<b>Cylindrical</b>	
<b>13-247</b>	<b>2 3/4" backset, deadlatch, square corner, 1 1/8" x 2 1/4"</b>
<b>Mortise</b>	
<b>09-663</b>	<b>Armor front, 1 1/4" wide, square corner</b>
See price book for mortise deadbolt and other backset and latch options or armor front options	
<b>13</b>	<b>Strike</b>
<b>Cylindrical</b>	
<b>10-025</b>	<b>1 3/16" lip, ANSI, no box, 1 1/4" x 4 7/8"</b>
<b>Mortise</b>	
<b>10-072</b>	<b>1 3/16" lip, 1 1/4" x 4 7/8" square corner, box</b>
See price book for other available strikes	
<b>14</b>	<b>Door thickness</b>
<b>1 3/4"</b>	
Other thicknesses available between 1 3/8" and 2 3/4"	
See price book for detail	

## Lever styles

Conventional cylinders shown, SFIC and FSIC also available.

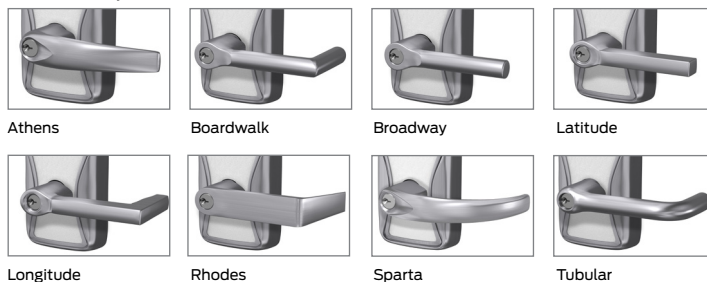

## About Allegion

Allegion (NYSE: ALLE) is a global pioneer in safety and security, with leading brands like CISA®, Interflex®, LCN®, Schlage®, SimonsVoss® and Von Duprin®. Focusing on security around the door and adjacent areas, Allegion produces a range of solutions for homes, businesses, schools and other institutions. Allegion is a \$2 billion company, with products sold in almost 130 countries. For more, visit [www.allegion.com](http://www.allegion.com).

KRYPTONITE ■ LCN ■ SCHLAGE ■ STEELCRAFT ■ VON DUPRIN

## Finishes

Warm tone finishes



Cool tone finishes

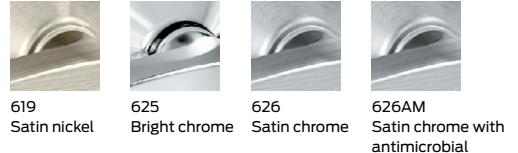

Allegion, the Allegion logo, Falcon, Schlage, the Schlage logo, and Von Duprin are trademarks of Allegion plc, its subsidiaries and/or affiliates in the United States and other countries. All other trademarks are the property of their respective owners.



© 2021 Allegion  
004446, Rev. 03/21  
[www.allegion.com/us](http://www.allegion.com/us)